

## VFS 10-200

Vortex flow sensor, 10-200 l/min



TM03 8209 0807

Fig. 1 VFS 10-200 sensor

### Technical overview

Grundfos Direct Sensors™, type VFS, are a series of combined flow- and temperature sensors (two-in-one) based on the principle of vortex shedding behind a bluff body. The VFS sensors are designed for high-volume production and are fully compatible with wet, aggressive media. The VFS sensor utilises MEMS sensing technology in combination with a novel packaging concept using corrosion-resistant coating on the MEMS sensor element. This makes the VFS sensor very robust and ideal for high-volume OEM applications. VFS sensors are available for flow ranges of 1.3-20, 2-40, 5-100 and 10-200 l/min.

The trademark Grundfos Direct Sensors™ is owned and controlled by the Grundfos group.

### Applications

- Burner control in domestic gas boilers
- Thermal management in solar heating systems
- Industrial process flow control
- Flow rate detection for pump controls
- Monitoring of pumps, valves and filters
- Cooling and temperature control
- Domestic hot-water stations.

### Features

- Flow ranges: 1.3-20, 2-40, 5-100 and 10-200 l/min.
- Designed for harsh environments
- Based on vortex shedding
- Voltage output (ratiometric, ideal for use with micro-processor and PLC)
- Compact and well-proven design
- MEMS sensing technology
- Approved for potable water: WRAS, NSF, KTW, W270, ACS.

### Benefits

- No moving parts
- Flow and temperature sensor in one package (two-in-one sensor)
- Fast temperature response (direct media contact)
- Compatible with wet, aggressive media
- Cost-effective and robust construction.

### Specifications

Pressure	
Range	10 to 200 l/min
Accuracy ( $\pm 1\sigma$ ), 0 to 100°C, >20 l/min	$\pm 1.5$ %FS
Accuracy ( $\pm 1\sigma$ ), 0 to 100°C, <20 l/min	$\pm 2.5$ %FS
Response time (63.2%)	< 1.5 s
Resolution	1.0 l/min
Temperature	
Range	0 to 100°C
Accuracy ( $\pm 1\sigma$ ), 25 to 80°C	$\pm 1$ °C
Accuracy ( $\pm 1\sigma$ ), 0 to 100°C	$\pm 2$ °C
Response time (63.2% at 50%FS flow)	< 1.5s
Resolution	0.5°C
Media and environment	
Media types	Liquids. The sensor is compatible with aggressive media.
Media temperature (operation)	0 to 100°C
Media temperature (peak)	-25 to 120°C
Ambient air temp. (operation)	-25 to 60°C
Ambient air temp. (peak)	-55 to 90°C
Humidity	0 - 95 % (relative), non-condensing
Burst pressure	> 16 bar
Electrical data	
Power supply	5 V DC ( $\pm 5\%$ ). Grounding of the sensor supply is recommended
Output signals	Ratiometric
Flow signal	0.35 - 3.5 V
Temperature signal	0.5 - 3.5 V
Power consumption	< 50 mW
Load impedance	> 10 k $\Omega$
Sensor materials	
Sensor element	Silicon-based MEMS sensor
Seal (sensor to housing)	EPDM rubber
Housing	Composites (PPS, PA66)
Flow pipe	PPA 40-GF
Wetted materials	Corrosion-resistant coating EPDM, PPS, PPA 40-GF
Environmental standards	
Enclosure class	IP44
Temperature cycling	IEC 68-2-14
Vibration (non-destructive)	20 - 2000 Hz, 10G, 4h
Electromagnetic compatibility	EN 61326-1
Dimensions	
Sensor element	47*40*20 mm
Flow pipe	137*45*41 mm

**Dimensions (in mm)**

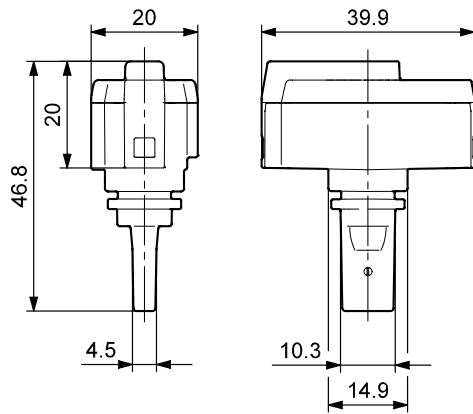

**Fig. 2** Dimensional sketches of sensor element

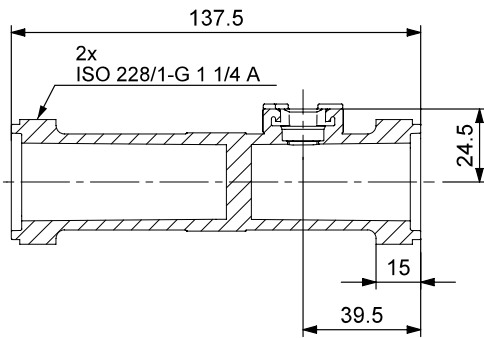

**Fig. 3** Dimensional sketch of flow pipe

**Type key**

The VFS sensor is labelled with a type designation.

	96642106	- XX	- XXX	XXXXX
Product number				
Revision				
Production year and week				
Consecutive number				

**Electrical connections**

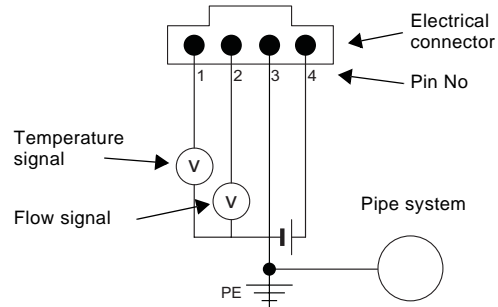
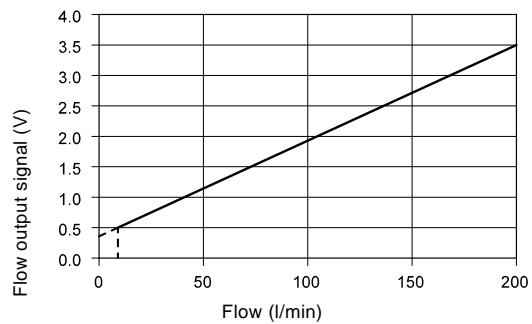

**Fig. 4** Electrical connections

**Pin configuration**

1	Temperature signal (0.5 to 3.5V relative to pin 3)
2	Flow signal (0.35 to 3.5V relative to pin 3)
3	GND (0V)
4	Voltage supply (+5V DC), PELV

**Sensor output signals**



**Fig. 5** Flow response

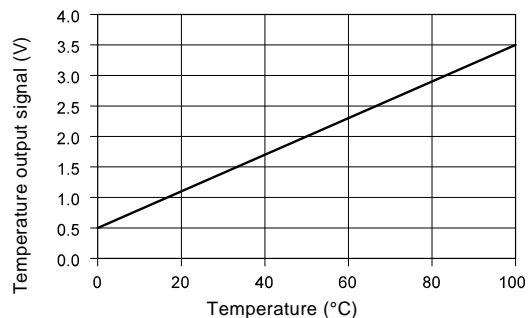

**Fig. 6** Temperature response

For more information, see <http://www.grundfos.com/directsensors>.

96702086 0207	GB
---------------	----

Subject to alterations.