

**DESCRIPTION**

Solenoid valve 2 way normally closed  
direct acting poppet type

**CONSTRUCTION**

Body	Brass
Armature tube	Brass
Plunger and core	Stainless steel
Springs	Stainless steel
Seal material	NBR
	FPM
	EPDM



**2**

**FEATURES**

Maximum allowable pressure 50 bar  
Maximum fluid viscosity 25cSt (mm<sup>2</sup>/s)  
Ambient temperature : with class F coil -10°C +55°C  
with class H coil -10°C +80°C  
Universal mounting position

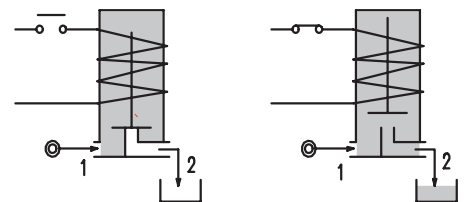
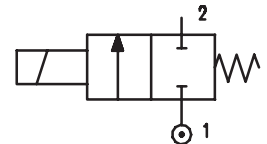

- OPTIONS :** Armature tube in stainless steel  
Electroless nickel plating  
Explosion proof coil according to ATEX - EExmII Series7  
Manual override  
Version for use with oxygen

CODE ① ②	Connection G ISO 228	Orifice mm	KV m <sup>3</sup> /h	Differential pressure bar			Nominal power			Coil		Seal ①	Temp. range °C
				Min	Max		AC Inrush	VA Holding	DC Watt	Series	Width		
					AC	DC							
E105A.....12///.....	1/8"	1.2	0.04	0	25	25	12	8	6.5	3	22	NBR=B	-10 +90
E105A.....15///.....	1/8"	1.5	0.06	0	16	16	12	8	6.5	3	22		
E105A.....20///.....	1/8"	2	0.09	0	12	10	12	8	6.5	3	22		
E105A.....25///.....	1/8"	2.5	0.14	0	8	5.5	12	8	6.5	3	22		
E105A.....31///.....	1/8"	3.1	0.19	0	5	2	12	8	6.5	3	22		
E105A.....40///.....	1/8"	4	0.35	0	4	1.5	12	8	6.5	3	22		
E105A.....20///.....	1/8"	2	0.09	0	25	15	15	11	5	4	30	EPDM=E	<+140
E105A.....25///.....	1/8"	2.5	0.14	0	16	8	15	11	5	4	30		
E105A.....31///.....	1/8"	3.1	0.19	0	8	4	15	11	5	4	30		
E105A.....40///.....	1/8"	4	0.35	0	5	2.5	15	11	5	4	30	FPM=V	-10 +130

- ① Seal  
② Coil

Example: E105AB20///30B NBR seal  
Coil 24V 50/60Hz

**Stig Wahlström AB**

Box 64, 123 22 Farsta  
Fax: 08 605 81 74, Tel: 08 683 33 00  
E-post: mailbox@wahlstrom.se  
Webbplats: www.wahlstrom.se

COILS	Alternating Current ~50/60Hz Volt							Direct Current Volt			Electrical connection	Connectors
	12	24	48	110	220 230	240	380	12	24	48		
Series 3 Width 22 Code ②	30A	30B	30C	30D	30E	30F	30G	300	301	302	DIN 46244	PG9 code 10348000
Series 4 Width 30 Code ②	40A	40B	40C	40D	40E	40F	40G	400	401	402	DIN 43650A	PG9 code 10349000

**DESCRIPTION**  
 Class F insulation  
 Voltage tolerance  
 AC +15% -10%  
 DC ± 10%  
 Protection class  
 IP65 with connector fitted  
 IP00 without connector  
 Continuous service ED100%

**OPTIONS**  
 Class H insulation  
 Cable attached  
 Special coil voltage  
 Special coil powers

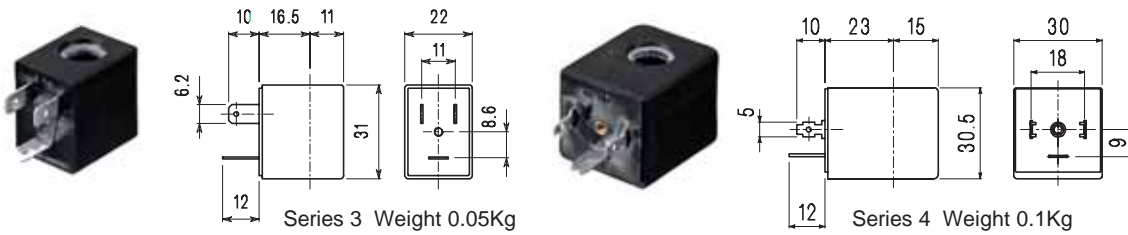

### SPARE PARTS LIST

1. Coil fixing nut
2. Coil
3. Plunger
4. Armature tube with core

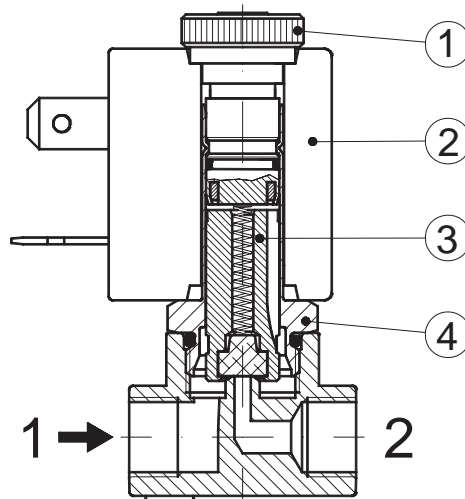

### MANUAL OVERRIDE

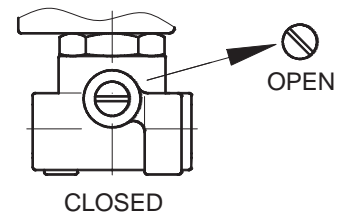

### OVERALL DIMENSION

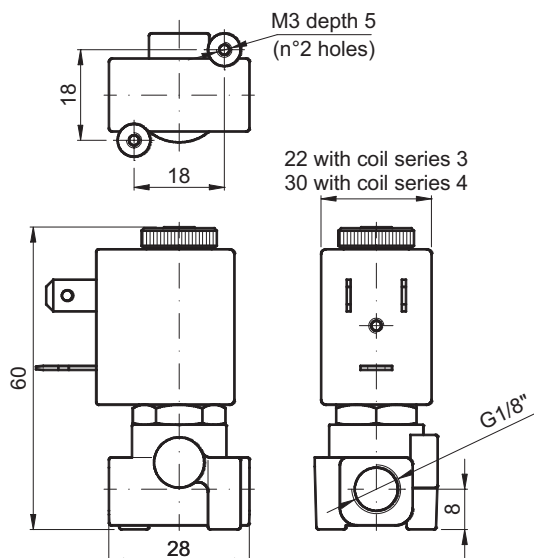

Weight with coil series 3 = 0.13 Kg  
 Weight with coil series 4 = 0.18 Kg