

## FS-4 0.4 - 6.0 (l/min)

PISTON TYPE

FLOW SWITCHES

www.gems-sensors.co.uk

### Pre-adjusted set points

The FS-4 Series makes flow protection economical for a broad range of industrial applications such as business machines, heavy duty floor cleaners, commercial dishwashers and beverage dispensing equipment.

### Specifications

(all data related to water at +20°C)

Max. flow	12 l/min
Max. operating pressure	20 bar
Proof pressure	30 bar
Max. temperature	+107 °C (Ambient +80°C for cable)
Set points	see order number
Switching function (related to increasing flow)	NC, NO, SPDT
Factory calibration position	vertical, inlet port down
Mounting orientation	Any position
Repeatability	± 1%
Adjustment accuracy	±15%
Hysteresis	max. 20%
Mounting	9/16"-18 UNF-2B, with adapter: G1/4"
Electrical connections	— lead wire: TPE, 18 AWG x 0.6m approx — cable: PVC, 0.34 mm <sup>2</sup> x 1m approx
Enclosure	IP 65
Electrical data contact rating	NC/NO: 100 VA; 3 A; 220 V~ SPDT: 20 VA; 0.5 A; 220 V~
Weight	0.1 kg



### Dimensions (in mm)

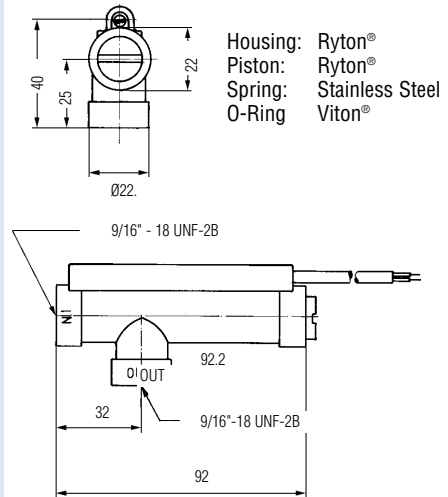

### Adaptors

Please use adaptor only in connection with supplied Viton O-Ring.  
 Brass Adaptor 9/16"-18UNF-2B to G 1/4" with Viton O-Ring **912-0616**

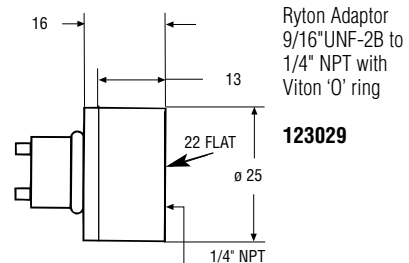
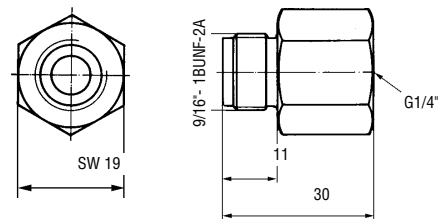

### How to Order

set points (l/min)	order number lead wire		
	NO	NC	SPDT
0.4	122340	122346	122352
1.0	122341	122347	122353
2.0	122342	122348	122354
3.0	122343	122349	122355
4.0	122344	122350	122356
6.0	122345	122351	122357

set points (l/min)	order number cable		
	NO	NC	SPDT
0.4	020-0242	020-0248	<b>020-0254</b>
1.0	020-0243	020-0249	<b>020-0255</b>
2.0	020-0244	020-0250	<b>020-0256</b>
3.0	020-0245	020-0251	<b>020-0257</b>
4.0	020-0246	020-0252	<b>020-0258</b>
6.0	020-0247	020-0253	<b>020-0259</b>

### Pressure drop diagram

(at min. set point adjustment)

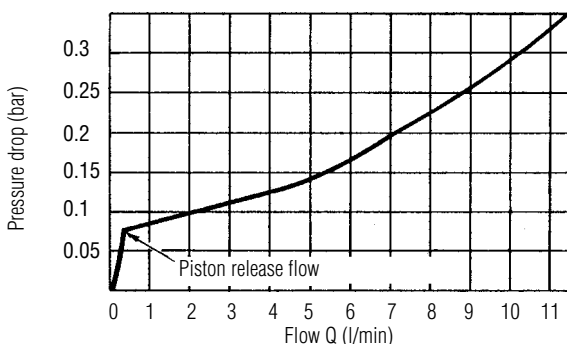

Standard Products in **bold**

### Wiring Diagram

