

FLOW SWITCHES

FS-400 3.0 - 37.5 (l/min) with pre-adjusted set points

FS-400A 3.0 - 53.0 (l/min) variable adjustment of set points

SHUTTLE TYPE

The FS-400 and FS-400-Adjustable switches provide 1% repeatability. The unit may be fitted instead of a pipe elbow where space is at a premium.

Specifications (all data related to water at +20°C)

Max. flow	55 l/min
Max. operating pressure	27 bar
Proof pressure	45 bar
Temperature range	- 20 °C...+150 °C
Set points	see order numbers
Switching function (related to increasing flow)	SPDT
Mounting orientation	any position
Factory calibration position	vertical, inlet port down, electrical connection up
Repeatability	± 1%
Adjustment accuracy	± 5%
Hysteresis	max. 15%
Mounting	3/4" NPT
Electrical connection	- lead wire: Polymeric, 18 AWG (length: approx. 0.6 m) - terminal box option see page FS-200
Enclosure	- IP 44 (with lead wire) - IP 54 (with terminal box) IP65 (with K6 box)
Electrical data contact rating	SPDT max. 20 VA, 0.5 A, 250 V~
Weight	0.8 kg

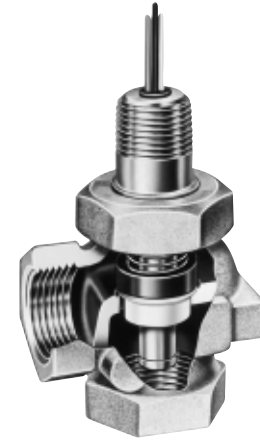

Dimensions (in mm)

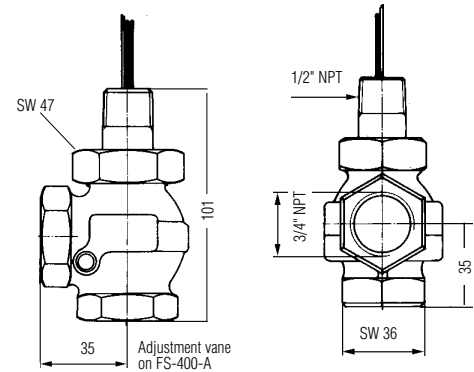

Housing: Bronze
Disc: Stainless Steel
O-Ring: Viton®
Spring: Stainless Steel
Magnet: PTFE/Ceramic

Wiring Diagram

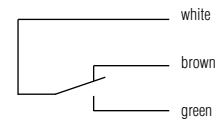

How to Order

Order numbers for FS-400

Set points (l/min)	Order number
3.0	022-6440
6.0	022-6441
7.0	022-6442
9.5	022-6443
19.5	022-6444
28.5	022-6445
37.5	022-6446

Order numbers for FS-400A

Set points (l/min)	Order number
3.0 ... 15.0	022-6600
7.5 ... 30.0	022-6601
26.5 ... 53.0	022-6602

*Order numbers are valid for units with the electrical connection "lead wire". If you need a unit with the electrical connection "terminal box", please select the respective "lead wire" order number and add: "...with mounted terminal box 912-0615 or 912-0625".

See drawing (page 57, FS-200)

Pressure Drop Diagram (at min. set point adjustment)

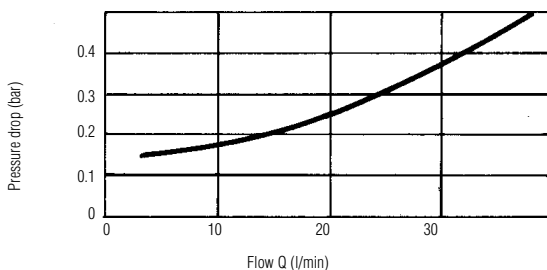

FLOW SWITCHES