

FS-550E 15.0 - 125.0 (l/min) with pre-adjusted set points

Standard FS-550E switches sense liquid flow in either direction to monitor flow/no-flow conditions. The paddle is trimmed during installation to permit switch actuation at the desired flow rate. As flow increases in a pipe, the paddle of the switch pivots to move out of the liquid path, producing less than 200mb of pressure drop regardless of pipe size.

Specifications (all data related to water at +20°C)

Max. flow	determined by the pipe's inside diameter
Max. operating pressure	55 bar
Proof pressure	82 bar
Max. pressure drop	0.2 bar
Temperature range	cable: -20 °C...+80 °C terminal box: -20 °C...+150 °C
Set points	see set point adjustment guideline
Switching function (related to increasing flow)	-SPDT
Mounting orientation	vertical, electrical connection up
Repeatability	±5%
Adjustment accuracy	±25%
Hysteresis	max. 50%
Mounting	R1"
Electrical connections	- cable: PVC, 3 x 0.34 mm ² (length: approx. 1 m) - terminal box
Enclosure	- IP 65
Electrical data contact rating	- SPDT max. 20 VA, 0.5 A, 250 V~
Weight	0.6 kg

How to Order

Electrical Connection	Brass	Stainless Steel
Cable	020-3493	020-3495
Terminal box	020-3497	020-3499

Set Point Adjustment (approximate)

Cut-off size	Pipeline sizes							
	1 1/2"		2"		2 1/2"		3"	
	Set points (l/min) with increasing and decreasing flow							
	incr.	decr.	incr.	decr.	incr.	decr.	incr.	decr.
1 1/2"	57	42	106	80	144	114		
2"			84	57	103	76	182	144
2 1/2"					80	53	152	99
3"							118	76

Mounting Method

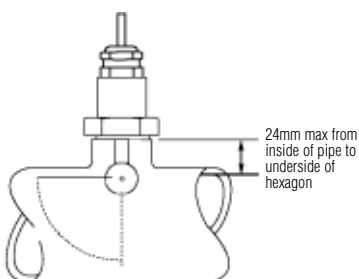

Wiring Diagram

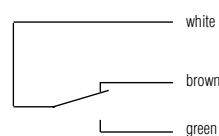

Standard Products in **bold**



Dimensions (in mm)

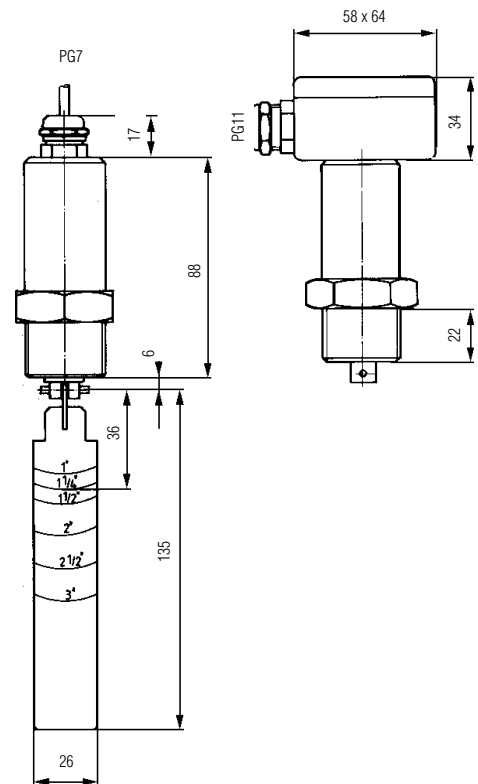

Housing: Brass or Stainless Steel
 Paddle: Stainless Steel
 Spring: Stainless Steel
 Magnet: PTFE

