



Series
SFI-800

Sight Flow Indicator/Transmitter

Low Cost, Optional Output for Flow Rate and Totalization
New UV Stabilized Polycarbonate Model



Flow

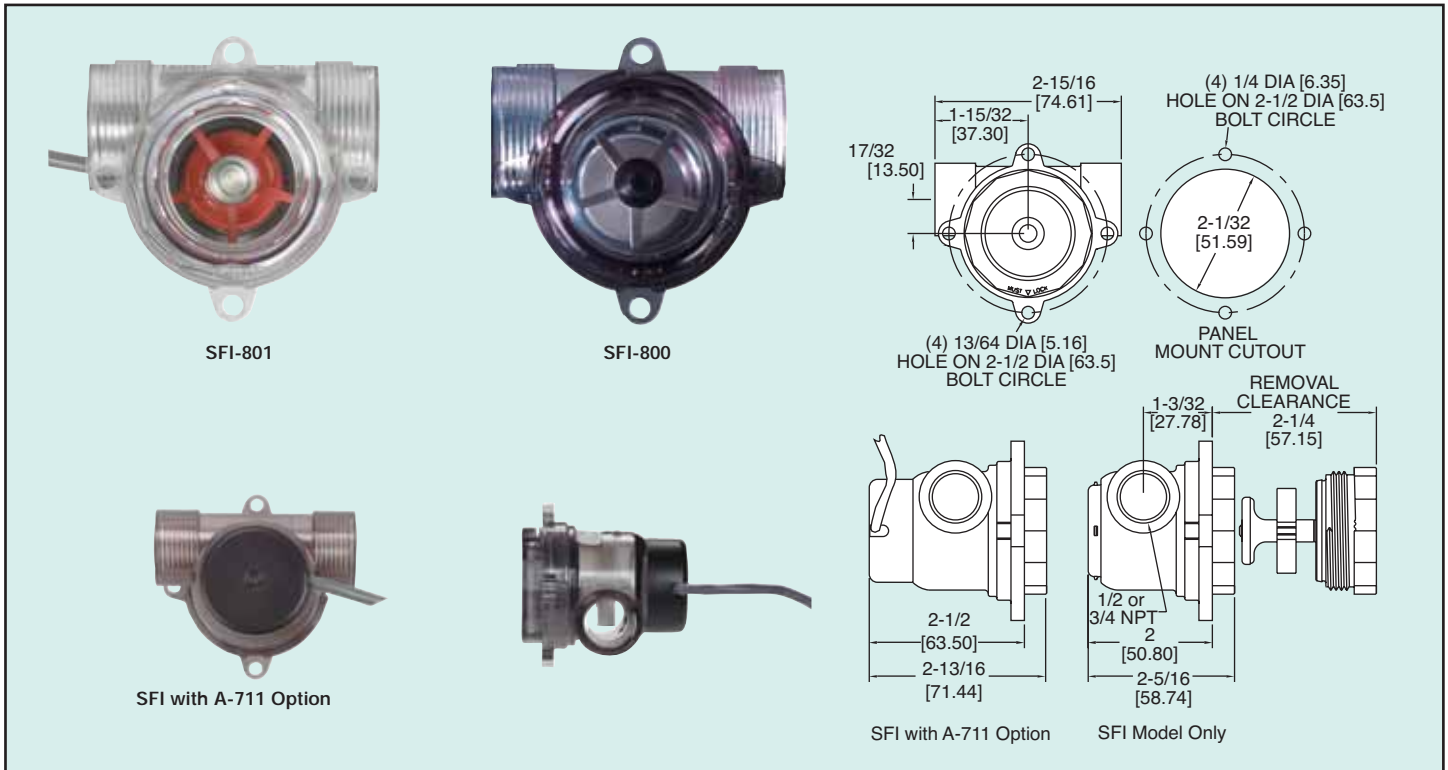

The Series SFI-800 Sight Flow Indicator is a low cost, durable rotor style flow indicator with optional Hall effect magnetic output packages for remote flow monitoring. Both SFI-800 and 801 models are constructed of clear plastic enabling 360° viewing of the spinning rotor for easy flow indication. SFI-800 models are constructed of Polysulfone with excellent chemical compatibility, high pressure and temperature ratings, and all wetted materials are FDA/NSF ratable for potable water applications. SFI-801 models are constructed of UV stabilized Polycarbonate making them ideal for outdoor applications (materials do not meet FDA/NSF). The SFI-801 models also feature an easy view bright red impeller.

OUTPUT PACKAGES

Three output sensors are available for the SFI-800 or 801 Sight Flow Indicators adding remote flow monitoring to local flow indication. All three packages can be easily installed onto an existing indicator body in the field without any tools. Sensors can also be replaced in the field without removing the body from the process line. Units are weather-tight for outdoor or wash-down area use.

The A-711 is a unique and patent pending sensor that outputs two pulsed voltage signals proportional to flow rate. Pulsed outputs are a 5 VDC pulse and a pulse of the input supply voltage used, which can be from 8 to 18 VDC. This sensor is perfect for remote monitoring of flow rate and flow totalization.

The A-712 is a sensor that outputs a linear 1 to 10 VDC signal proportional to flow rate. The sensor is good for remote flow rate monitoring. The A-713 is a sensor with two programmable open collector switch outputs. One output is closed above the set point and the other output is closed below the set point allowing the unit to be used for low flow or high flow indication. The setpoint is easily set by pushing a button at the desired flow rate. Sensor includes red LED indication of switch status.

FEATURES

- Easy viewing of flow indicator with clear plastic housing
- Output sensors can be added and replaced in the field without removing body from the process line
- No magnets in the rotor to attract ferrous materials
- Materials that can be FDA approved or UV stabilized

APPLICATIONS

- Monitor chilled or hot water flow
- Great for use in monitoring water flow in chillers

Stig Wahlström AB

Box 64 · 123 22 Farsta · Fax 08-605 81 74 · Tel 08-683 33 00
E-post: mailbox@wahlstrom.se Webbplats: www.wahlstrom.se

SPECIFICATIONS

Service: Compatible fluids.

Wetted Materials:

Body: SFI-800: Polysulfone, SFI-801: UV Stabilized Polycarbonate.

Window: SFI-800: Polysulfone, SFI-801: UV Stabilized Polycarbonate.

Rotor: SFI-800: White Polysulfone, SFI-801: Red UV Stabilized PBT.

Rotor Pin: 316 SS.

Thrust Washers: 300 Series SS.

O-Ring: SFI-800: Fluoroelastomer (NSF Grade), SFI-801: Buna-N.

Temperature Limits: SFI-800: -20 to 212°F (-29 to 100°C); SFI-801: -20 to 130°F (-29 to 55°C).

Pressure Limits: SFI-800: 150 psi (10.34 bar); SFI-801: 125 psi (8.62 bar).

Viscosity Max: 200 SSU.

Weight: SFI-800: 3.35 oz (95 g); SFI-800-A711: 5.0 oz (142 g).

ELECTRICAL SPECIFICATIONS (for A-711 Option Only)

Temperature Limits: -20 to 212°F (-29 to 100°C).

Power Requirements: 8 to 28 VDC.

Output Signal: White lead: 5 VDC. Green lead: 8 to 28 VDC equal to supply voltage. Pulsed output with frequency rate proportional to flow rate.

Accuracy: ±5% of F.S.

Frequency Output Range: 0 to 100 Hz.

Electrical Connections: Black lead - Ground; White lead: 5 VDC out pulse; Green lead: 8 to 28 VDC out pulse; Red lead: 8 to 28 VDC supply.

ELECTRICAL SPECIFICATIONS (for A-712 Option Only)

Temperature Limits: -20 to 212°F (-29 to 100°C).

Power Requirements: 15 to 28 VDC.

Output Signal: White lead: 1 to 10 VDC.

Accuracy: ±5% of F.S.

Electrical Termination: Black lead: Ground; Red lead: 15 to 28 VDC input; White lead: 1 to 10 VDC output.

ELECTRICAL SPECIFICATIONS (for A-713 Option Only)

Temperature Limits: -20 to 212°F (-29 to 100°C).

Power Requirements: 8 to 28 VDC.

Output Signal: White lead: Normally open switch; Green lead: Normally closed switch. Both open collector, 100 mA max, 28 VDC max.

Electrical Connections: Black lead: Ground; White lead: Normally open; Green Lead: Normally closed; Red lead: 8 to 28 VDC.

Model Number	Description	Range GPM (LPM)	Connection Female NPT
Polysulfone Body			
SFI-800-1/2	Indicator Only	2 - 20 (7.6 - 75.5)	1/2"
SFI-800-3/4	Indicator Only	3 - 35 (11.4 - 132.5)	3/4"
SFI-800-1/2-LF	Indicator Only	0.5 - 6.5 (1.9 - 24.6)	1/2"
Polycarbonate Body			
SFI-801-1/2	Indicator Only	2 - 20 (7.6 - 75.5)	1/2"
SFI-801-3/4	Indicator Only	3 - 35 (11.4 - 132.5)	3/4"
SFI-801-1/2-LF	Indicator Only	0.5 - 6.5 (1.9 - 24.6)	1/2"

Model Number	Description
A-711	Pulsed Output
A-712	1 to 10 VDC
A-713	Two Open Collectors

BODY AND SENSORS ATTACHED:

To order **A-711** attached to flow indicator body add suffix -A711 to the body part number.

Example: **SFI-800-1/2-A711**

To order **A-712** attached to flow indicator body add suffix -A712 to the body part number.

Example: **SFI-800-1/2-A712**

To order **A-713** attached to flow indicator body add suffix -A713 to the body part number.

Example: **SFI-800-1/2-A713**